

Wiring Diagram

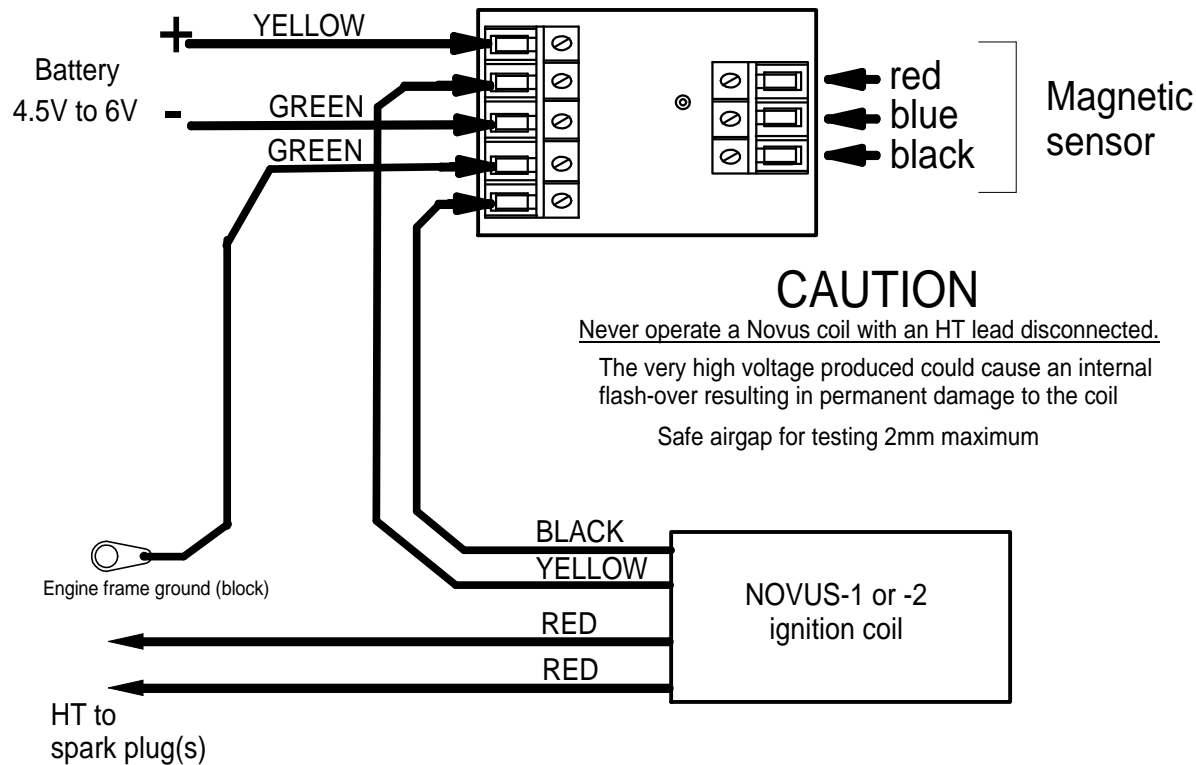

Outline Drawing and Data

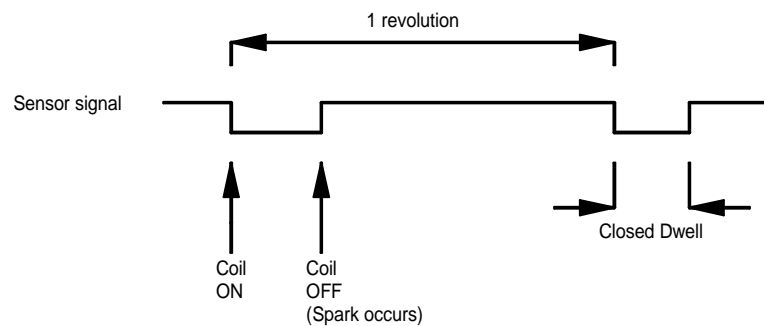
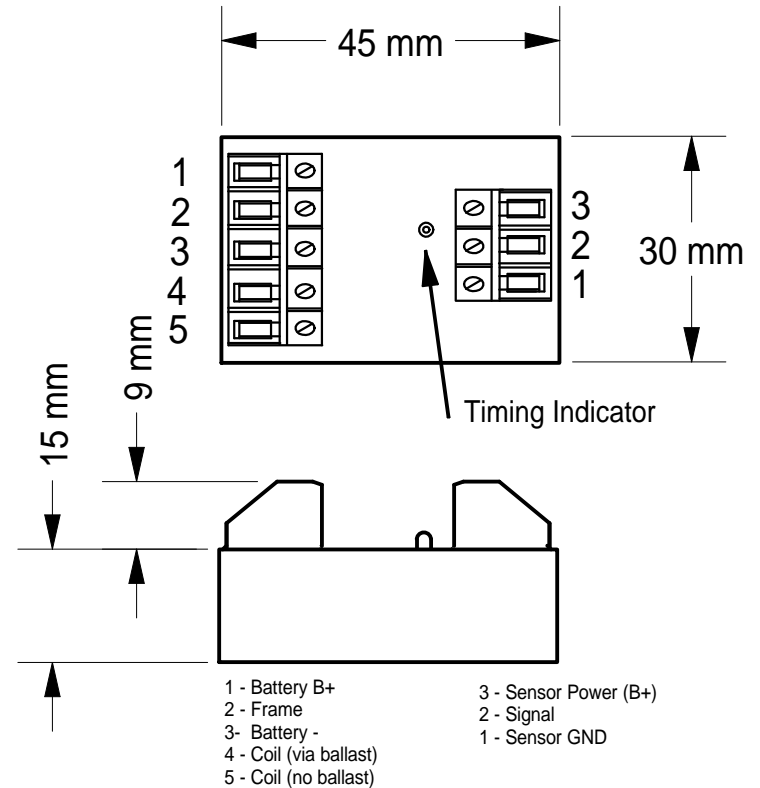

Supply voltage range 4.5V to 12V, maximum current 11A (pulsed)
 Power saver - If the engine stops with the sensor active, coil is switched off after about 0.5 seconds
 Use heavy gauge wire for all coil connections.
 A battery capable of delivering high currents should be used eg. lead-acid or a NiCd pack.
 Dwell
 Very important! To ensure sufficient spark energy, arrange closed dwell to be about 1.5 milliseconds at maximum desired RPM with a 6 volt supply. A longer dwell wont harm.
 Built-in static timing light is useful for checking. On = sensor active, spark occurs at switch-off.
 Example using a crankshaft mounted sensor magnet:
 Max RPM = 6000.
 = 100 rev/sec
 = 10ms per rev.
 Need 1.5ms closed dwell, so sensor needs to be active for at least
 $1.5/10 \times 360 = 54$ degrees

DRWN jk	CHKD	Date 4 Feb 2011	Minimag Co. Lingfield, Surrey. Made in England	1 24/10/11 Changed wiring detail
DRWG 1 of 1	File MIC1A+Novus.fcwREV2			Minimagn Ignition Controller Type-1A Connections when used with Novus coils Outline & Connections